

BIJLAGE 4: ELEKTRICITEIT AAN BOORD

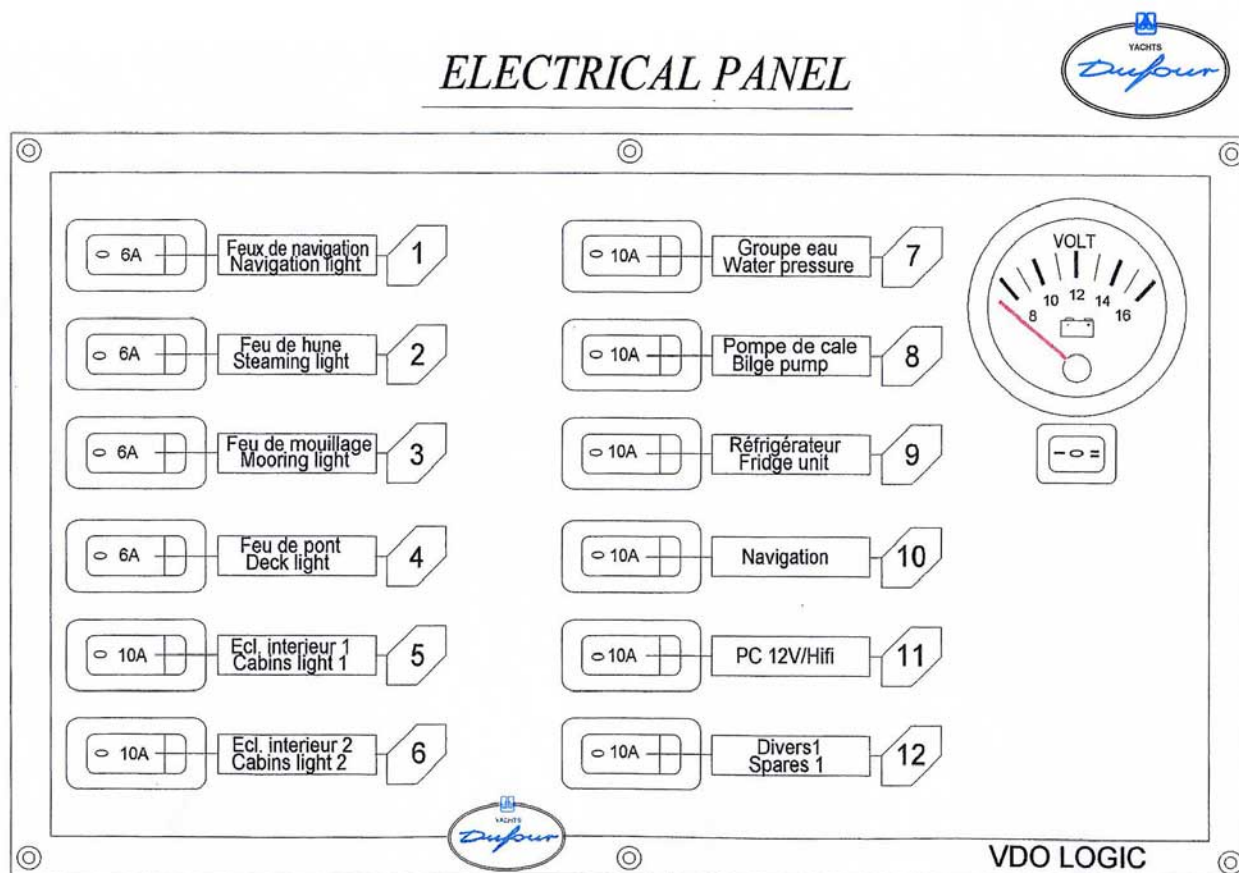

Nr.	Omschrijving	Automaat; Ampère
1	Navigatieverlichting (driekleur – toplicht)	6
2	Stoomlicht (rood/groen – halverwege de mast)	6
3	Ankerlicht (wit rondschijnend toplicht)	6
4	Deklicht (niet aanwezig / niet aangesloten)	6
5	Kajuitverlichting:	10
6	Kajuitverlichting:	10
7	Waterpomp	10
8	Bilgepomp	10
9	Koelkast	10
10	Navigatieapparatuur	10
11	Radio/CD-speler	10
12	Reserve; <i>opmerking: 16 ampère en geen 10 Ampère zoals in de tekening</i>	16
	Accuvoltmeter met 2-standen schakelaar / stand I slechts benut	

Opmerking:

De toegepaste schakelaars zijn feitelijk stroomverbrekers.

Bij een te hoge stroom wordt de stroomkring door deze stroomverbreker automatisch onderbroken. Door de stroomonderbreker te bedienen (aan/uit) wordt de stroomkring weer hersteld.

Fabriek E-T-A; 3130-F110-P7T1-W12QR3

VDO Logic Panel
Schematisch

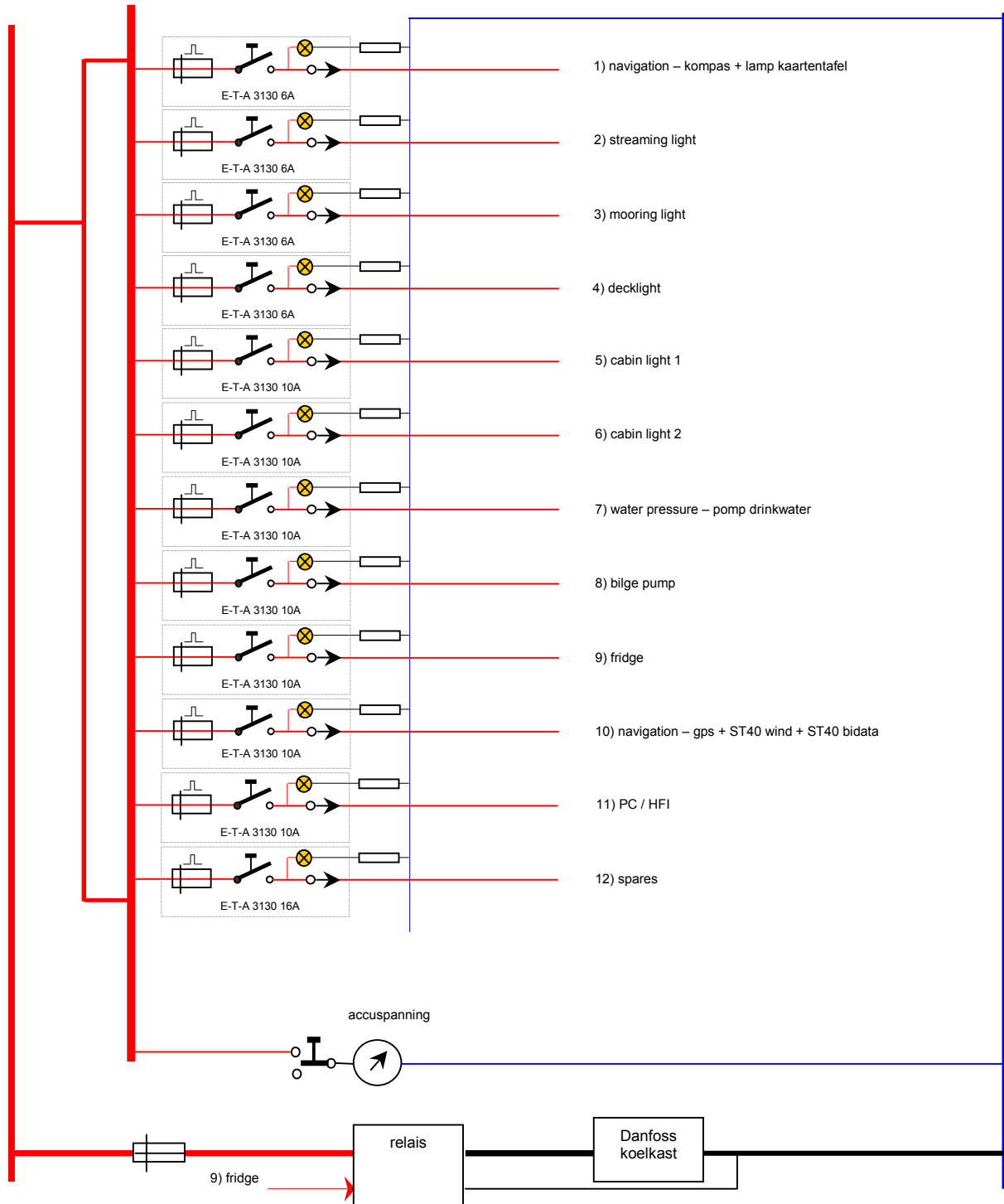

Navigation lights

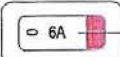
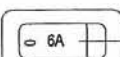
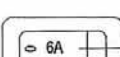

Sailing

-  Feux de navigation
Navigation light 1
-  Feu de hune
Steaming light 2
-  Feu de mouillage
Mooring light 3

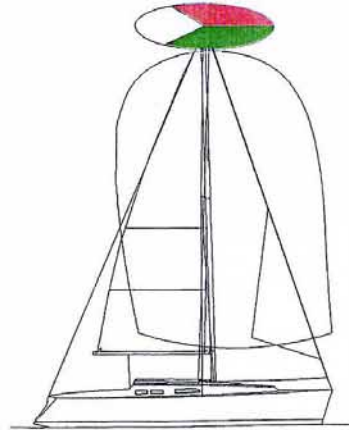

Mooring

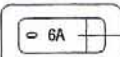
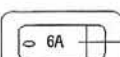
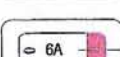
-  Feux de navigation
Navigation light 1
-  Feu de hune
Steaming light 2
-  Feu de mouillage
Mooring light 3

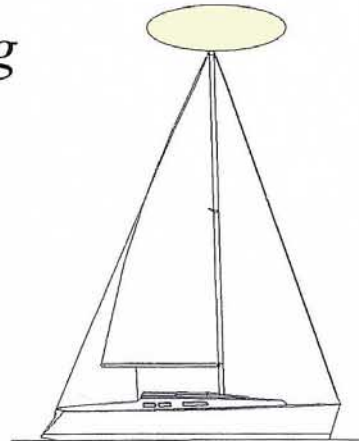

Motor

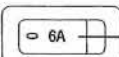
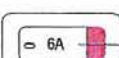
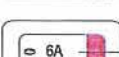
-  Feux de navigation
Navigation light 1
-  Feu de hune
Steaming light 2
-  Feu de mouillage
Mooring light 3

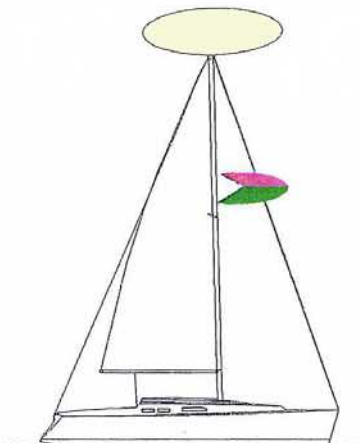

CHARGE WIRING

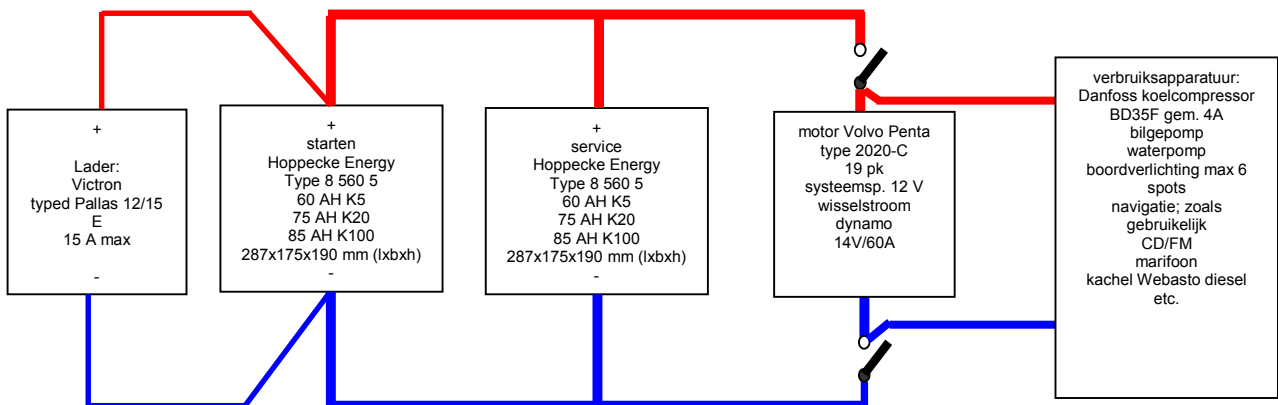
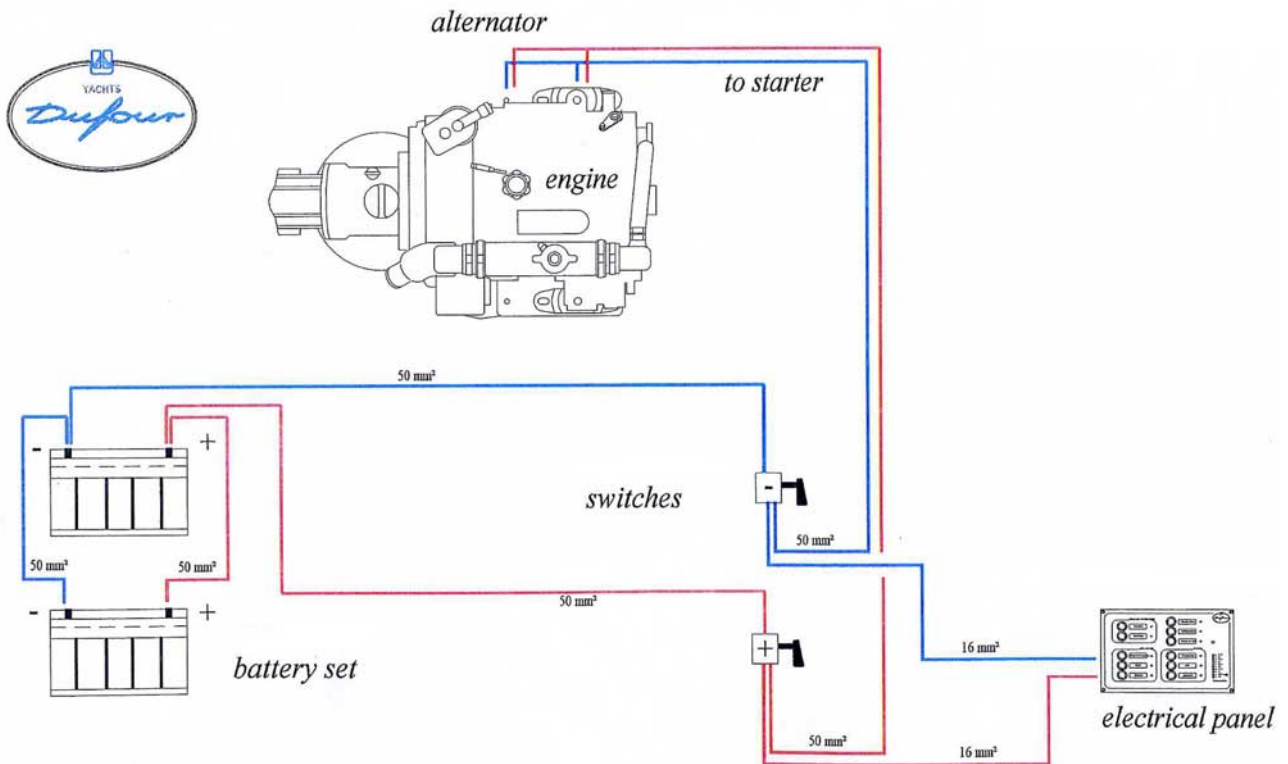

Elektrisch - Leidingloop

ELECTRICAL WIRING

